

JARECKI VALVES INSTALLATION AND MAINTENANCE MANUAL

W SERIES THREE PIECE BI-DIRECTIONAL METAL SEATED BALL VALVE

INSTALLATION

Before Installation, the piping system should be cleaned and flushed, to prevent damage to the seats. Next, ensure that the valve has not been damaged during shipment. All flange protectors and shipping materials must be removed to allow a thorough inspection.

W series valves can be supplied in socket weld, threaded, and flanged ends.

The Limiting Stops on the Actuator are Factory Set. Cycle the valve operator to ensure that it has not been damaged. There should be no hesitation or jerkiness to the stem movement.

The valve may be installed into the piping system with the valve stem oriented either vertically or horizontally depending on the piping arrangement. If the valve is installed horizontally, it is strongly recommended that the actuator be pointing upwards and not sideways. When hoisting the valve into position, **never pick up the valve by the operator.**

WELDING PROCEDURE FOR WELD END VALVES

1. Do **not** disassemble the valve.
2. Apply Anti-Heat, or some other heat-sink compound to the outer boundary of the Heat Affected Zone. The Heat Affected Zone is approximately 2" in length, in either direction of the weld area.
3. Ensure that the area to be welded is free of grease and dirt.

4. Grounding straps should be used and strapped onto the tail piece that is being welded on for each tail piece.
5. Weld the valve per applicable procedures, taking care to keep the temperature as low as possible past the heat affected zone. At no time should the temperature exceed 300 deg (the max temp for 300 series SST inter pass temperature) in the area outside the heat affected zone.

OPERATION

Jarecki W Series Ball Valves are primarily used as shut-off valves. If the valves are to be used for control, it is strongly recommended that the factory be contacted.

If the valve is lever operated, turn the lever clockwise to close and counterclockwise to open. If the lever is perpendicular to the flow, the valve is closed. There are stops set on the valve for both the open and closed positions.

If the valve is operated by an actuator, the instruction manual for this equipment will need to be reviewed for proper operation.

MAINTENANCE

This valve does not require lubrication or maintenance. If a leak occurs at the body and tailpiece connection, the valve will need to be repaired.

No scheduled maintenance on the stem packing is required, however, regular inspection is recommended. During maintenance, if leaking is discovered around the stem packing you can tighten the stem packing. This can be accomplished with the

valve in line. After the stem nut has been tightened, if leaking persists, the stem packing should be changed. **There should be no pressure on the valve when the stem packing is changed.**

1. Unsecure the stem lock washer (19) by bending the ear down.
2. Tighten the stem nut (18) just enough to stop the packing leak. Care must be taken not to over torque the stem nut. See the below chart for average torque settings. Do not exceed the numbers in the chart by over 50%.
3. Secure the stem lock washer (19) by bending one ear up against the flat of the nut

2250 WOG

1/2"	3/4"	1"	1 1/2"	2"
3	3	4	5	6

torque in ft.lbs

4500 WOG

1/2"	3/4"	1"	1 1/2"	2"
4	5	6	8	8

torque in ft.lbs

DISASSEMBLY

Jarecki Valves recommends returning metal seated valves to our factory concerning major repairs. A spare parts kit can be purchased for this valve. If valve disassembly becomes necessary in the field, proceed as follows:

1. Before removing the valve from the line, be certain the line pressure in the piping system has been depleted.
2. Cycle the valve while it is still in the line to remove any possible trapped pressure within the body cavity.
3. Match mark position of all mating parts prior to removal.
4. Remove valve from the line, setting the valve down horizontally. The valve should be supported in some fashion to prevent it from tipping over.
5. If applicable, mark the actuation with the serial number listed on the valve tag. Remove actuator assembly. With a wrench, stroke the valve so that it is in the open position.
6. Loosen the lever nut (51) and remove the hand lever (50). Remove the stem lock washer (19), stem

nut (18), Belleville washers (17) and compression ring (11).

7. Remove the body bolts (7) from the tail pieces (5) and separate the tail pieces from the body (4).
8. Remove the ball (1), stem (9) and thrust washer (10) from the inner body cavity. Remove the inner (6A) and outer body gaskets (6B) from both sides of the body (4).
9. Remove the seat (2B) from the tail (5).
10. Remove the seat seal (3A) from the seal seat (2B).
11. Remove the stem packing (14A). When removing packing, a nonmetallic pick should be used to prevent possible scratching of the packing box sealing surface.
12. Inspect all components and repair or replace as required. All seals should be replaced once disassembled.

ASSEMBLY

1. Thoroughly clean valve body and components with a solvent.
2. Place body (4) so that the flow direction arrow is facing down. Place cardboard or some other material under the other end in order to protect that area. Install the inner (6A) and outer body (6B) gaskets on the body.
3. Place the non-serrated tailpiece (5) so that the seat cavity is facing up. Place cardboard or some other material under the weld end in order to protect the area. Place the guide spring (3C) and (non-serrated) guide seat (2A) in the non-serrated tailpiece (5).
4. Install the body bolts (7) through the tail (5) and thread in to the body (4).
5. Flip the body (4) and tail (5) assembly over so that it is resting on the weld end of the tail, ensuring the weld end is protected with cardboard or some other suitable material. Install the inner (6A) and outer body gaskets (6B) on the body. Insert seat seal (3A) and seal seat (2B).
6. Insert the thrust washer (10), followed by the stem (9) into the body. Next, insert the ball (1) into the body cavity.
7. Place the tailpiece (5) so that the seat cavity is facing up. Place cardboard or some other material under the weld end in order to protect the area. Place the seat seal (3A) and seal seat (2B) in the tailpiece (5).

8. With the flow direction arrow on the body (4) now pointing in the upward direction, place the serrated tailpiece (5) and its internal components on to the body and install the body bolts (7).

Uniformly tighten all body bolts on both tail pieces at this time per the following:

9. Insert the Jarecki supplied stem packing (14A) into the packing box by installing each packing ring individually, and carefully pushing each ring into place with the compression ring (11).

10. Install the compression ring (11), Belleville washers (17), stem lock washer (19) and stem nut (18) respectively. Snug the stem nut down only finger tight at this point.

11. Cycle the valve to ensure it is functioning properly. There should be no sticking or jerking motion. Tighten the stem nut (18) until the Belleville washers become flat. It is very important not to over torque the stem packing.

12. Attach the actuation assembly.

13. Operate valve to ensure it is functioning properly.

BODY BOLT TORQUE CHART	
VALVE SIZE	TORQUE FT.LBS
1/2"	12 FT.LBS
3/4"	12 FT.LBS
1"	32 FT.LBS
1 1/2"	55 FT.LBS
2"	60 FT.LBS

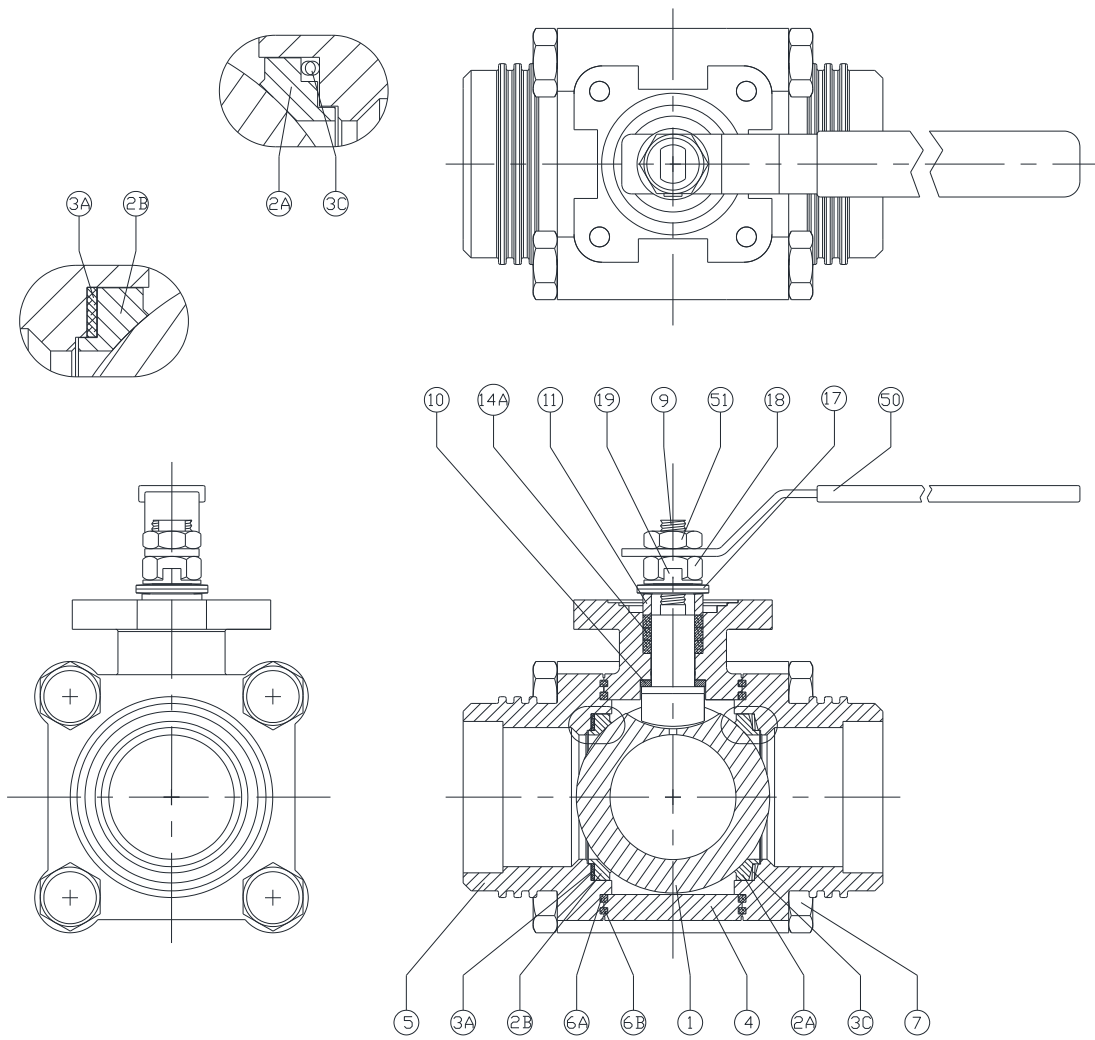

ITEM	DESCRIPTION	QTY
1	Ball	1
2B	Sealing Seat	2
3A	Seat Seal	2
4	Body	1
5	Tailpiece	1
6A	Inner Body Seal	2
6B	Outer Body Seal	2
7	Body Bolt	8,16 or 24
9	Stem	1
10	Thrust Washer	1
11	Compression Ring	1
14A	Stem Packing	1 set
17	Belleville Washer	1 set
18	Stem Nut	1
19	Stem Lock Washer	1
50	Handlever	1
51	Lever Nut	1

Jarecki Valves
 6910 West Ridge Road
 Fairview PA 16415
 Tel: 814-474-2666
 Fax: 814-474-3645